

ACCESSORY LIST

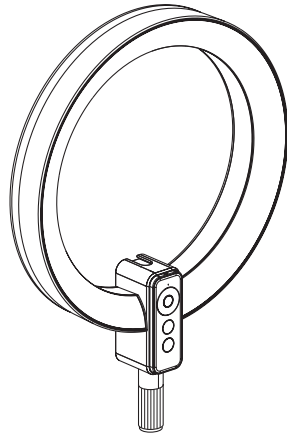

X 1
12" Ring Light

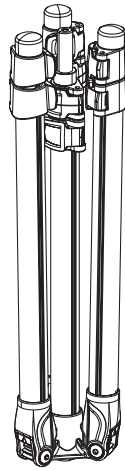

X 1
Tripod



X 1
1/4 Ball Head Interface

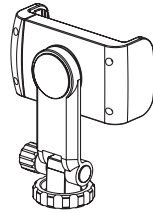

X 1
Phone Holder

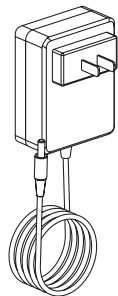

X 1
Power Adapter

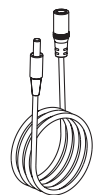

X 1
Extension Cord

SPECIFICATIONS

| | |
|------------------------------------|---------------------|
| Product Name | Live Stand |
| Product Mode | LT-2LH |
| Input | 12V 2A |
| Output | 5V 2A |
| Illuminance | 1700LUX |
| Color Temperatures | 2800~5500K |
| Applicable to | Phone/Camera/Webcam |
| Work Temperature | -10~40°C |
| Product Size | 394*345*167mm |
| Net Weight | 1.9KG |
| Gross Weight | 2.72KG |
| Remote-control Distance | ≤ 8m |
| Battery Capacity fo Remote Control | 55mAh |
| Supported System | Android/IOS |
| Enerprise Standards | Q/NBJHUP 001-2022 |

FEATURES

Your new Viozon LED Stand Light is a perfect light source for portrait and beauty photography with many features and benefits:

- 3 Color Lighting Modes:Cool White, Warm White and Warm Yellow
- Stepless adjustment of color temperature and brightness
- Convenient remote control & controller
- Upgraded tripod stand for increased stability
- 24W power adapter for better lighting effect
- 360° rotation for any shooting angle without limitations
- Easy to assemble

CAUTION

- Do not disassemble the device without authorization.
- Do not store the product in a high temperature environment.
- To avoid any damage to the tripod stand, do not place excessive force on it.
- When adjusting the tripod stand, make sure the clips and the buckles are unlocked. When using the tripod stand, make sure the clips and the buckles are locked.

WARRANTY SERVICE

Never worried when you choose viozon products We offer the best after-sale service to our customer, it only takes a few minutes.

Just send your name and order number to

 **US:** service@vio-zon.com
EU: support@vio-zon.com

And then you will get a complete service like The installation guide, Technical support, New product iteration, buy New similar products in advance , promotions, and warranty service from Viozon.

FEEDBACK

Share it?
Let us know with a customer review.

Viozon is focus on high-standard product, we believe Customer drive our product upgrades. And write a review that sharing your experience will help other customers , and this will give us great encouragement and confidence.

And if you have any questions, please feel free to contact us without hesitate.

FOR HELP PLEASE CONTACT US:

 **E-mail:** US service@vio-zon.com EU support@vio-zon.com

 **Facebook:** [Viozon](#)

 **Website:** www.vio-zon.com

viozon®

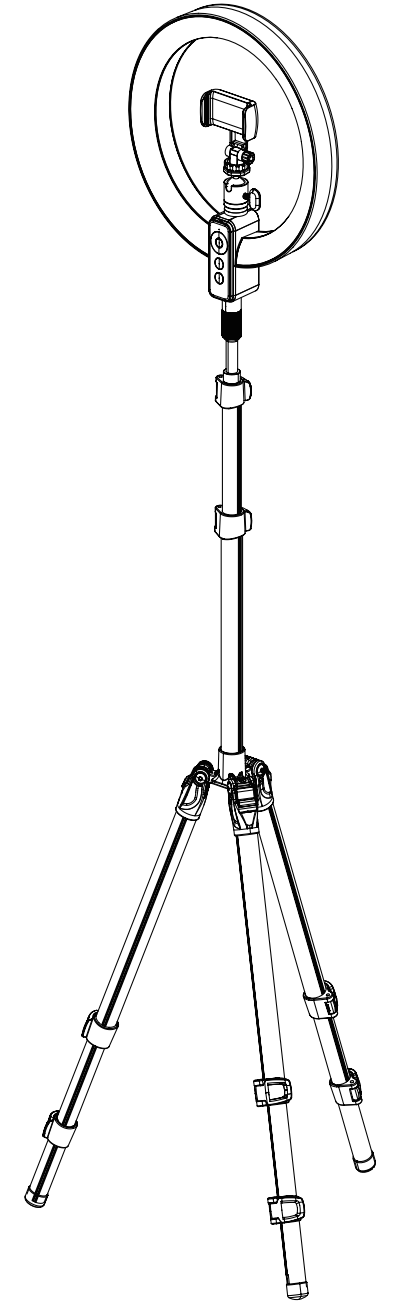

LT-2LH Installation Instructions

REMOTE DESCRIPTION



Lighting Mode

With light on, repeatedly short press to cycle through 3 lighting modes.



Ambient light switch

Press once to turn ambient light on/off.



Brightness +/-

With light on, repeatedly short press to increase / decrease brightness (5 levels).

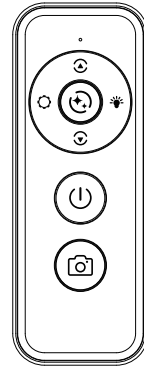

Ring light switch

Press once to turn ring light on/off.



Power On/Off

Press once to turn on/off.



Camera

- Short press to take photos.

Bluetooth Pairing

- Press and hold to pair with your Bluetooth device.

REMOTE CONTROL INSTRUCTION

1 Turn on Pairing

Press and hold the camera button for 2 sec, the blue flashing light flashes and product goes into the pairing status.

2 Bluetooth Pairing

1.Turns on your phone Bluetooth function in setting, search the pairing device with name"DOXG-A2" and click to pair.

2.The blue light off after the device paired successfully.

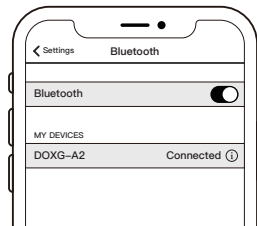

3 Recording Video/ Take Photo

1. Open the camera on phone
2. Press the camera button on remote control to take photo or record video.

NOTE: Without any operation, the product will enter sleep mode after 300 sec. Press the camera button to activate the sleep state.

4 Shut down Bluetooth

Press and hold the camera button for 2 sec. The blue light flashes quickly and Bluetooth function will be shut down.

1.TRIPOD STAND

1 Unfold the tripod legs. Adjust to the desired width.

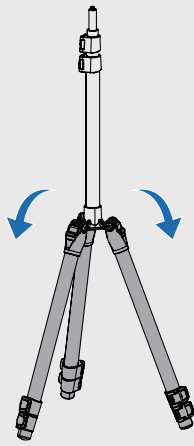

2 Lock the Adjustable Clip to its place.

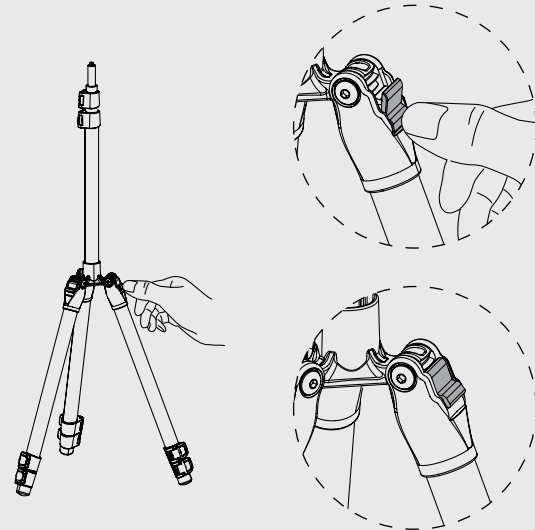

3 Loosen the buckles. Adjust to desired height and lock.

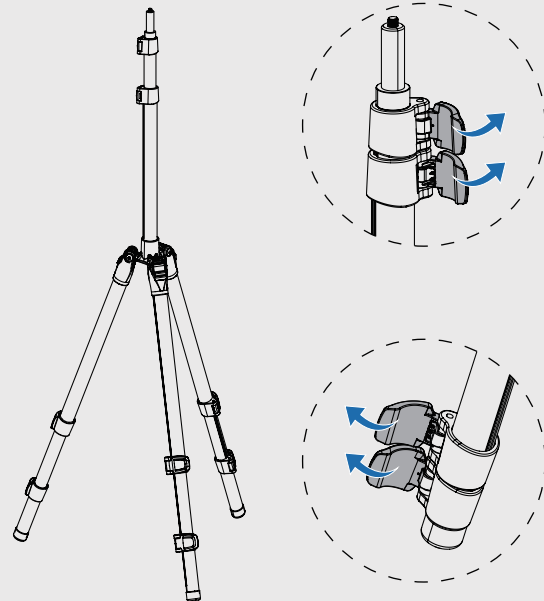

2.RING LIGHT AND PHONE HOLDER

1 Unscrew the Threaded Joint. 2 Fully insert the Ring Light 3 Screw tightly.

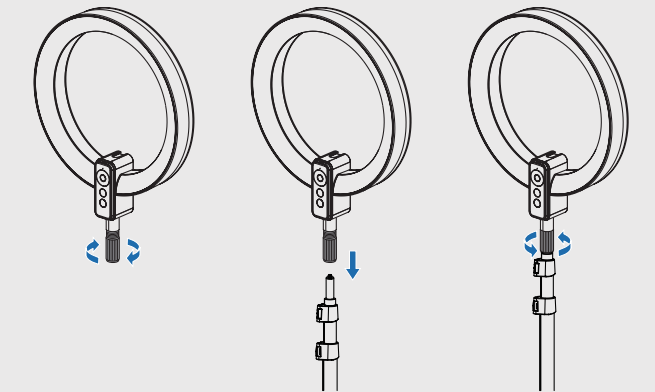

4 Slide ball head interface into light base, then tighten the screw.

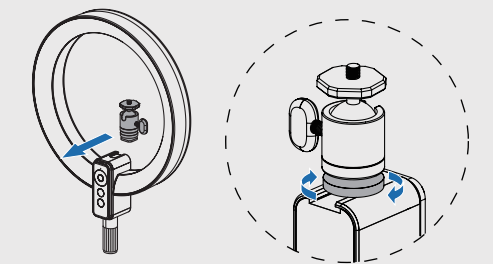

5 Screw phone holder into light base.

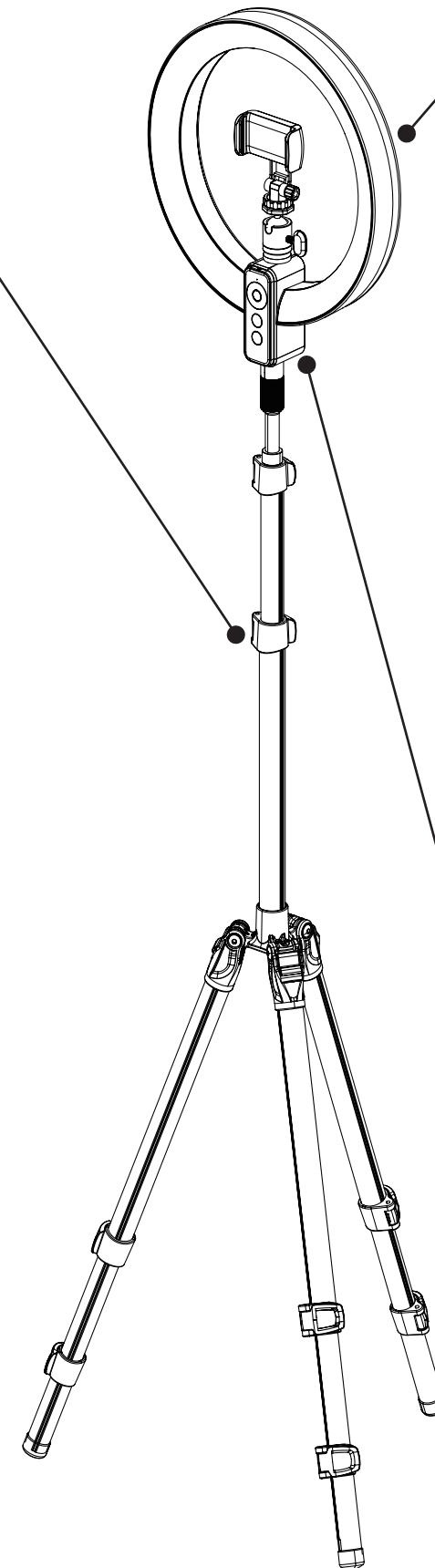
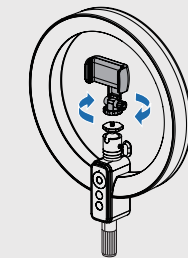

3.CONNECT THE POWER SUPPLY

1 Connect to power adapter. 2 Plug into an appropriate electrical outlet.

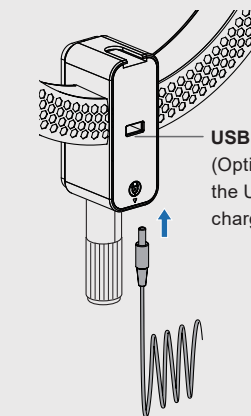

USB Output Port
(Optional) Connect to the USB output port to charge your device.

